

# HYGHSPIN

## BASIC

Compact Jung twin screw pump for free-flowing products

## Flexible use – maximum efficiency: Gentle product handling plus CIP with one and the same pump!

### Product transport

Gentle, smooth product handling, abrasion-free for maximum product protection

### CIP cleaning

Proven HYGHSPIN technology – no additional pump for CIP cleaning required



### Flexible design

Available as block design pump  
or with bare shaft



**JUNG**  
PROCESS SYSTEMS

hygienic · gentle · economical

## The efficient solution for free-flowing products

The HYGHSPIN Basic is the standard model in the internationally proven HYGHSPIN series of stainless steel pumps. The HYGHSPIN Basic is suitable for use with free-flowing products of almost any consistency (whether aqueous, highly viscous, lumpy, fibrous or gaseous) and works with maximum efficiency. This particularly servicing-friendly screw pump with its outstandingly high suction performance gently handles all free-flowing products in volumes up to 300 m<sup>3</sup>/h. No additional pump for CIP cleaning is required, which offers considerable time and cost savings thanks to lower investment and servicing costs.



The HYGHSPIN Basic ensures maximum flexibility and is available in block design or with bare shaft.

### Further benefits of the HYGHSPIN Basic

- **Considerable cost savings**  
Reduced investment and maintenance costs
- **Outstanding quality**  
Made entirely from stainless steel
- **Exceptionally maintenance-friendly**  
No need to remove the pump from the system for maintenance work
- **Maximum flexibility**  
Wide range of products, viscosities and volumes can be handled with just one pump
- **Gentle and uniform product handling**  
Low speed, minimum pulsation, no surges
- **Extremely high hygiene standards**  
No dead spaces and particularly effective flushing of the shaft seal
- **CIP and SIP**  
Cleaning and sterilisation in place, use as CIP feed pump

Twin screw pumps have clear advantages over other pumps such as centrifugal, rotary lobe and gear pumps, particularly in terms of their high flexibility and gentle, low-pulsation feed.

The HYGHSPIN Basic is available in block design in sizes 50, 70 and 90, and with bare shaft in sizes 70, 90 and 125. Delivery pressure up to 35 bar.



### Pump outlet / inlet

- Reversible pumping possible
- Horizontal discharge for perfect emptying
- Various standards and nominal widths available

### Four guide bolts with cap nuts

- Rapid assembly/disassembly for inspection and manual cleaning
- Guide bolts for damage-free handling of the components

### Product-contact surfaces

- Electro-polished for optimum cleaning (Ra < 0.8)
- Optional: Ra < 0.4

### Static seals

- Hygienic sealing with form rings
- No dead spaces
- FDA-approved elastomers in various qualities

### Pumping elements

- Balanced pumping elements
- Speed control from 5 to 130 Hz
- Product handling and cleaning with one pump
- Excellent suction performance and low NPSHr values
- Gentle axial product feed
- Pumping of lumpy media
- Pumping of media with gaseous content
- Optional: Kolsterised surface

### Pump outlet / inlet

- Reversible pumping possible
- Various standards and nominal widths available

### Bearing support

- Stainless steel with high-performance bearings

### Synchronisation gearwheels

- Inspection opening with access to gear unit
- Adjustment of flank clearance possible in place without discharging the gear oil

### Drive shaft

- Bare shaft or block design linked directly to the drive unit

### Gear casing

- Aluminium design with wear-resistant and acid-resistant Teflon coating
- Optional: Stainless steel design

HYGHSPIN

### Connections

- Flushing of the mechanical seal

### Positioning

- Exact positioning of the components thanks to precise manufacturing

### Pump housing

- Wear-resistant Jung chromium carbide coating
- Optional: Kolsterised surfaces

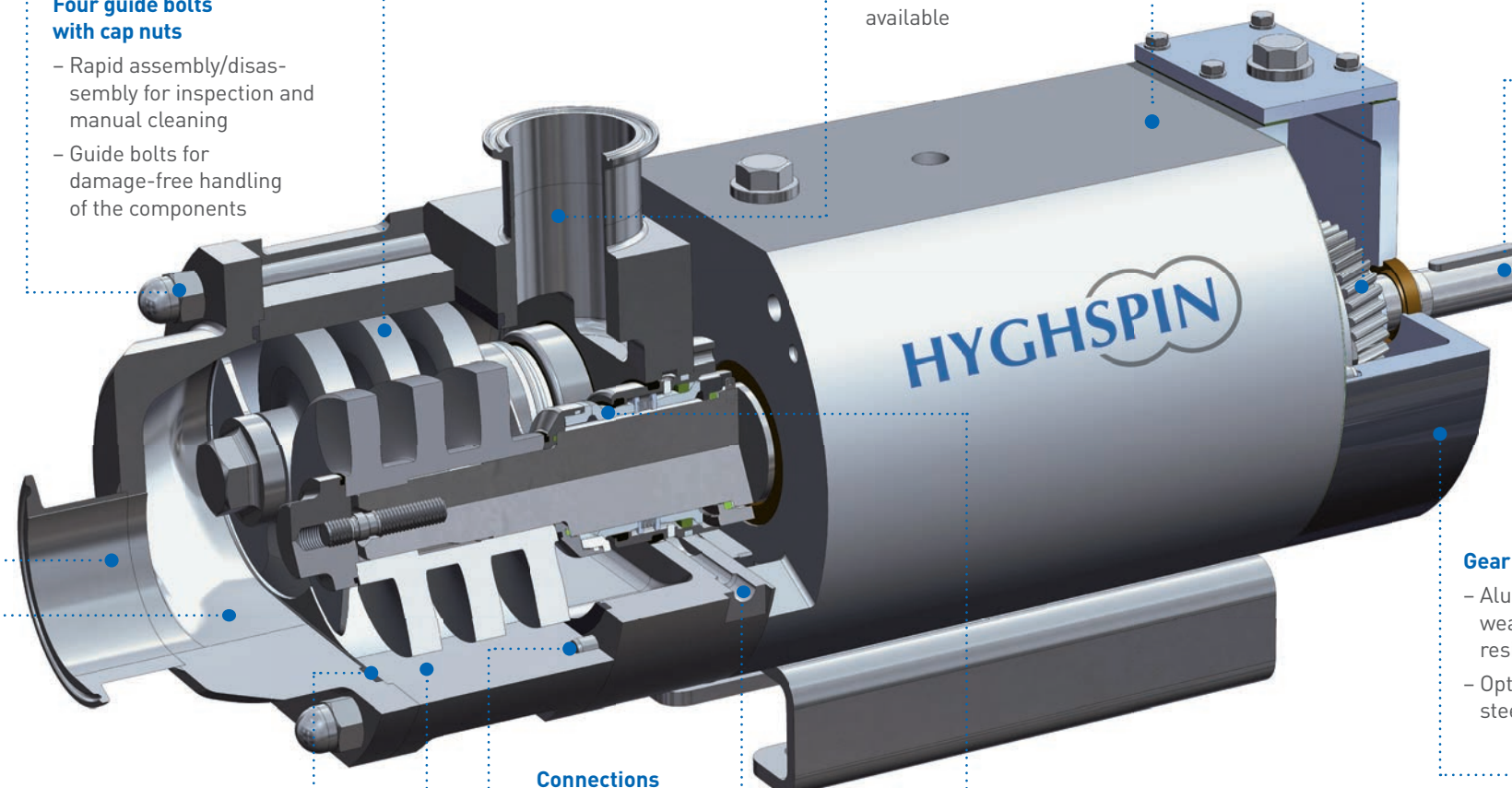

## Jung Process Systems – experience and competence

Jung Process Systems has been a specialist manufacturer of stainless steel screw pumps since 2009 and offers outstanding quality as well as far-reaching competence in the field of pump technology. The company manufactures twin screw pumps for all requirements and sectors and offers comprehensive worldwide support.

All pumps in the HYGHSPIN series are extremely compact, space-saving and maintenance-friendly. They offer high availability with minimum downtimes for maintenance work (optimal MTTR).

All models are based on the principles of hygienic design and therefore meet the required quality standards for use in the food, beverage, cosmetics, bio-pharmaceutical and chemical industries. The company's in-house production facilities offer logistical flexibility with reduced delivery times and a quality management system certified to ISO 9001:2008.



## HYGHSPIN – a screw pump for numerous industries

HYGHSPIN screw pumps are used in a wide range of industries – and deliver outstanding results:

- **Food manufacturing,**  
e.g. dairy industry, delicatessen products, ketchups and sauces, confectionery and baby food
- **Beverage manufacturing,**  
e.g. fruit juices, syrups and concentrates, breweries
- **Pharmaceutical industry**
- **Cosmetics industry,**  
e.g. creams, pastes, lotions
- **Chemical industry,**  
e.g. adhesives, solvents, paints and varnishes, plastics

And in many other industries where materials with a wide range of viscosities need to be transported.



## Technical data

Design	Block design		
Typ	HYGHSPIN 50	HYGHSPIN 70	HYGHSPIN 90
Capacity	30 l/h–15 m³/h	100 l/h–30 m³/h	1 m³/h–80 m³/h
Max. diam. of solids	16 mm	30 mm	45 mm
A	495 mm	650 mm	785 mm
B	108 mm	200 mm	148 mm
C	224 mm	295 mm	334 mm
D	156 mm	209 mm	275 mm
E	250 mm	350 mm	350 mm
F	149 mm	199 mm	259 mm
G (radial)	DN25–DN50 1"–2"	DN40–DN80 1.5"–3"	DN50–DN100 2"–4"
H (axial)	DN25–DN65 1"–2.5"	DN40–DN100 1.5"–4"	DN50–DN125 2"–5"
Weight	37 kg	68 kg	150 kg

Design	Bare shaft		
Typ	HYGHSPIN 70	HYGHSPIN 90	HYGHSPIN 125
Capacity	100 l/h–30 m³/h	1 m³/h–80 m³/h	10 m³/h–300 m³/h
Max. diam. of solids	30 mm	45 mm	67 mm
A	615 mm	723 mm	1004 mm
B	124 mm	146 mm	212 mm
C	252 mm	342 mm	491 mm
D	209 mm	275 mm	280 mm
E	199 mm	259 mm	249 mm
G (radial)	DN40–DN80 1.5"–3"	DN50–DN100 2"–4"	DN65–DN150 2.5"–6"
H (axial)	DN40–DN100 1.5"–4"	DN50–DN125 2"–5"	DN80–DN150 3"–6"
Weight	65 kg	128 kg	365 kg

## Performance features

Capacity	30l/h – 300 m³/h
Delivery pressure	Up to 35 bar
Suction capacity	NPSHr up to 0.5 m
Viscosity	0.5 – 1.000.000 cSt
Product temperature	-10 to 130 °C, (higher temperatures on request)
Cleaning temperature	Up to 140 °C
Sterilisation temperature	Up to 145 °C
Material for product-contact parts	1.4404 with 3.1 certificate (other materials on request)
Elastomers	HNBR and FDA-approved (other elastomers on request)

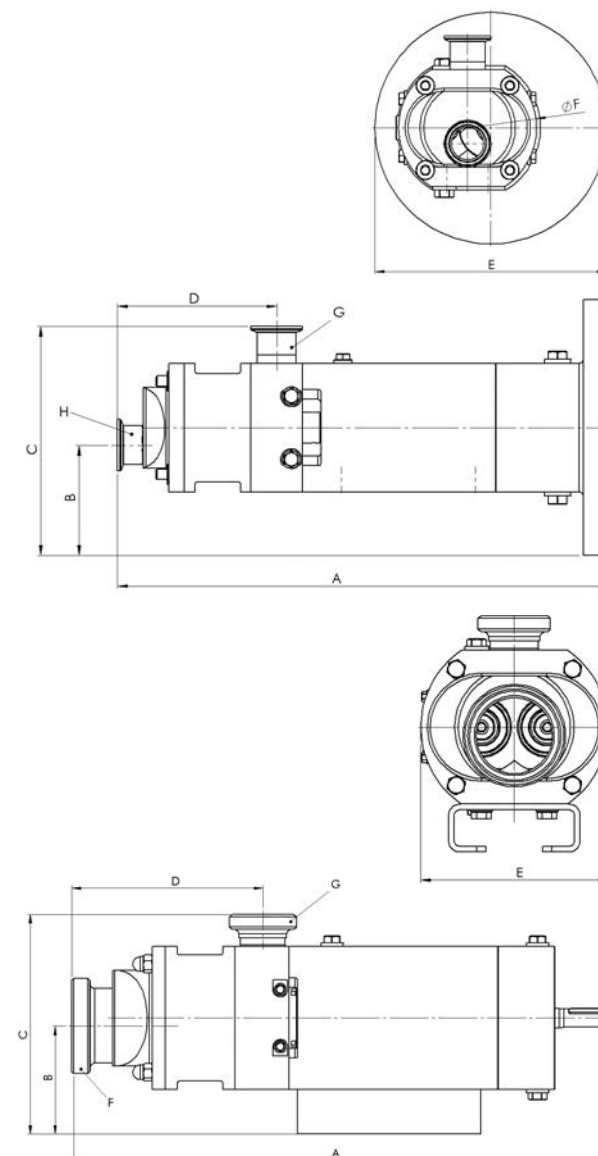

**JUNG**  
PROCESS SYSTEMS

Jung Process Systems GmbH

Auweg 2 · 25495 Kummerfeld  
Deutschland

Tel.: +49 4101 7958-140  
Fax: +49 4101 7958-142

info@jung-process-systems.de  
jung-process-systems.de